



OPERATING WEIGHT	9.2 t
ENGINE OUTPUT	74.5 kW (102 hp)
BUCKET CAPACITIES	1.5-3.0 m <sup>3</sup>
TIPPING LOAD, STRAIGHT	6.57 t
TIPPING LOAD, ARTICULATED	5.78 t



## Wheeled Loader TL160

### Technical data

Engine	
Manufacturer, model	Perkins, 1104C-44T
Type	4-cylinder turbocharged diesel engine, COM II/EPA II
Combustion	4-stroke cycle, direct fuel injection
Displacement	4400 cm <sup>3</sup>
Net power rating at 2250 rpm (ISO 9249)	74.5 kW (102 hp)
Cooling system	Water
Electrical system	
Nominal voltage	24 V
Lighting system in compliance with German and European standards.	
Power transmission	
Hydrostatic drive, closed circuit, independent from loader hydraulics. Perfected driving automatics, automatic adjustment of drawbar pull and speed. Hydraulic motor power shift providing two speed ranges. Infinitely variable speed control forward and reverse. 4-wheel drive from reduction gear on rear axle via cardan shaft to front axle. Brake inching pedal.	
<b>2 speed ranges:</b>	
"Low"	0-6 km/h
"High"	0-20 km/h
<b>4 speed ranges (high-speed version optional):</b>	
"Low"	0-6 / 0-20 km/h
"High"	0-12 / 0-40 km/h
Axles	
<b>Front:</b> Rigid planetary final drive axle. Limited slip-type differential.	
<b>Rear:</b> Oscillating (with cushioning) planetary final drive axle, with integrated reduction gear. Limited slip-type differential.	
Oscillation	± 12°
Tires	
Standard	15.5-25 EM 60 12 PR
Option	15.5-25 R 25 GP-2B L2 Goodyear
Option	15.5 R 25 XHA Michelin
Option	17.5 R 25 XHA Michelin
Option	17.5-25 EM SGL 12 PR Goodyear
Non-standard tires available on request	
Brakes	
<b>Service brake:</b> Hydraulically actuated two-circuit power brake system. Oil-immersed multi-disc brakes in both axles, acting on all 4 wheels via 4-wheel drive.	
<b>Auxiliary brake:</b> Hydrostatic drive provides dynamic braking.	
<b>Parking brake:</b> Spring-loaded brake acting on the discs of both axles.	
Steering	
Articulated, 2 steering cylinders with final positioning damping on both sides, fully hydraulic through Load-Sensing priority valve, quick and easy steering even at engine idle-running speed.	
Total steering angle	80°
Fluid Capacities	
Fuel tank	140 l
Hydraulic system (incl. tank)	93 l

### Operating data, standard equipment

Operating weight (ISO 6016)	9200 kg
Tipping load, straight, arms horizontal (ISO 14397-1), directly mounted / QAS	6575 / 6215 kg
Tipping load, articulated, arms horizontal (ISO 14397-1), directly mounted / QAS	5780 / 5440 kg
Total length, bucket on ground	6690 mm
Total width	2300 mm
Turning radius at outside bucket edge	5395 mm
Wheelbase	2760 mm
Total height (top of cab)	3050 mm

### Hydraulic system

Max. pump capacity	99 l/min
Max. working pressure	280 bar
<b>Control unit:</b> Proportional hydraulic valve with 3 control circuits. Simultaneous, independent control of all movements. Single, four-way control lever (multi-function lever) for 1 tilt and 2 lift cylinders with integrated travel direction selector switch and switch for additional control circuit. Float position in control circuit "Lowering", electro-hydraulically operated. Additional control circuit electrically operated with preselection of flow rate and impulse/continuous operation.	

### Loader frame

Loader frame with TSP-linkage, attachments directly mounted.	
General-purpose bucket (ISO 7546)	1.60 m <sup>3</sup>
Lift capacity at ground level (ISO 14397-2)	85,500 N
Breakout force at bucket edge (ISO 14397-2)	86,000 N

### Fork Lift Attachment

Payload over the total lift and steering range	3200 (3500)* kg
Payload in transport position, approx. 300 mm above ground level, total steering range	3500* kg
Width of fork carrier	1900 mm
Length pallet forks (140x50 mm)	1120 mm
Stability factor	1.25
Payload determined on level ground = 80 % of tipping load, articulated	

### Cab

Rubber-mounted full-vision steel cab, ROPS (acc. to ISO 3471) and FOPS (acc. to ISO 3449) certified.	
Cab featuring two doors, electric windshield intermittent wipers and washer (front and rear), tinted panoramic safety glass, sliding window on left-hand side.	
Driver's seat with hydraulic cushioning and lap belt, weight-adjustable, in compliance with ISO 7096 and ISO 6683.	
Cab heating with 3-speed heater fan (choice fresh air/recirculating air) and windshield defroster, front and rear.	
Automatic climate control.	
Tilt adjustable steering wheel.	
Radio pre-installation.	
2 front and 2 rear working floodlights.	
Sound level values in compliance with EC-directives.	
*With rear axle weights	

# Wheeled Loader TL160

## Dimensions: General-Purpose Bucket

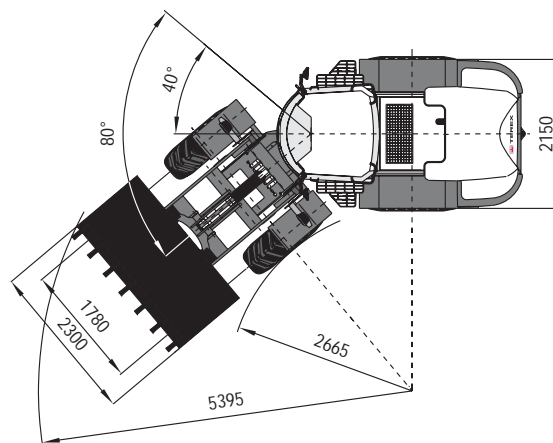
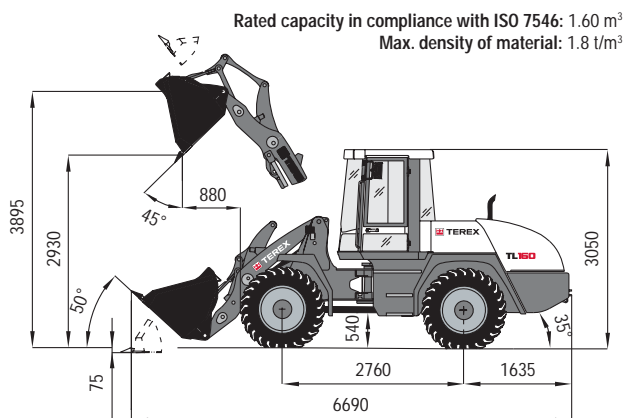

## Fork Lift Attachment

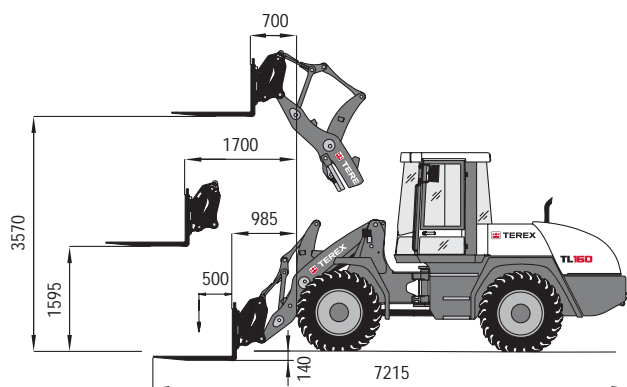

Payload over total lift range: 3200 kg  
Nutzlast, Transportstellung: 3500 kg

## Multi-Purpose Bucket

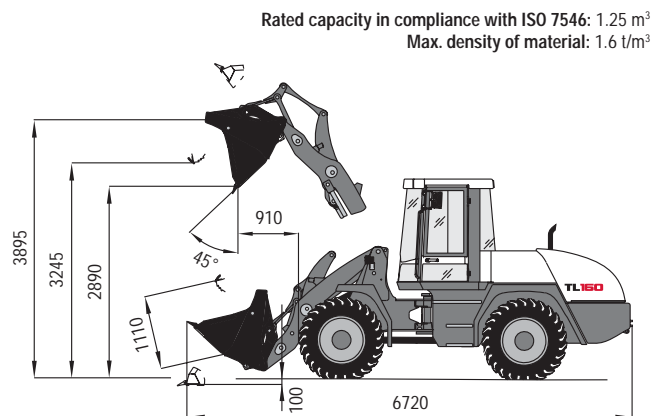

## Bucket Type

	Capacity	Density	Width	Dump height
General-purpose bucket, QAS	1.50 m <sup>3</sup>	1.8 t/m <sup>3</sup>	2300 mm	2890 mm
General-purpose bucket, QAS, bolt-on cutting edge	1.50 m <sup>3</sup>	1.8 t/m <sup>3</sup>	2300 mm	2850 mm
General-purpose bucket, directly mounted	1.60 m <sup>3</sup>	1.8 t/m <sup>3</sup>	2300 mm	2930 mm
General-purpose bucket, directly mounted, bolt-on cutting edge	1.60 m <sup>3</sup>	1.8 t/m <sup>3</sup>	2300 mm	2890 mm
Earth bucket, QAS	1.70 m <sup>3</sup>	1.6 t/m <sup>3</sup>	2300 mm	2890 mm
Earth bucket, QAS, bolt-on cutting edge	1.70 m <sup>3</sup>	1.6 t/m <sup>3</sup>	2300 mm	2790 mm
Earth bucket, directly mounted	1.80 m <sup>3</sup>	1.6 t/m <sup>3</sup>	2300 mm	2800 mm
General-purpose bucket, directly mounted, bolt-on cutting edge	1.80 m <sup>3</sup>	1.6 t/m <sup>3</sup>	2300 mm	2760 mm
Multi-purpose bucket, QAS	1.25 m <sup>3</sup>	1.6 t/m <sup>3</sup>	2300 mm	2890 mm
Multi-purpose bucket, QAS, bolt-on cutting edge	1.25 m <sup>3</sup>	1.6 t/m <sup>3</sup>	2300 mm	2850 mm
Light-material bucket, QAS, bolt-on cutting edge	2.20 m <sup>3</sup>	1.2 t/m <sup>3</sup>	2300 mm	2740 mm
Light-material bucket, QAS, bolt-on cutting edge	2.60 m <sup>3</sup>	0.8 t/m <sup>3</sup>	2500 mm	2710 mm
High-tip bucket	1.50 m <sup>3</sup>	1.2 t/m <sup>3</sup>	2300 mm	4360 mm
<b>Examples of Material Densities</b>				
Granite, Sand (damp), Gravel (damp):	1.8 t/m <sup>3</sup>	Coal, Slate:		1.2 t/m <sup>3</sup>
Earth (damp), Sand (dry), Gravel (dry):	1.6 t/m <sup>3</sup>	Coke, Wood chips (dry):		0.8 t/m <sup>3</sup>



Terex GmbH Schaeffstrasse 8  
D-74595 Langenburg, Germany

PHONE +49 (0)7905 / 58-0 FAX +49 (0)7905 / 58114  
EMAIL info@terex-schaeff.com WEB terex-schaeff.de